

RFIDRW-E-232E

Enhanced Animal tag and RFID reader writer with external antenna.

The RFIDRW-E-232E is a RFID reader module capable of reading animal tags using the FDX-B and HDX protocols as described by ISO11784/11785. In addition it will read and write other transponder types as specified below.

- **Suitable with the following transponders:**
 - EM4100 read only compatible transponders.**
 - Atmel T55xx series of Read/Write transponders.**
 - Read/Write FDX-B and HDX Protocol as defined in ISO11784/11785 for animal identification.**
 - TIRIS 64 bit and Multi-page transponders:**
 - RI-TRP-R... 64 bit Read Only**
 - RI-TRP-W... 80 bit Read/Write**
 - RI-TRP-D... 1360 bit Multi-page 17 pages Read/Write**
 - Reads and Writes EM4205 / EM4305 transponders.**
 - Biphase Encoding 32 cyc/bit.**
- **Serial RS232 Output and Input on a DB9 connector.**
- **Small unit size: 66mm x 37mm**
- **Output control for a dual color LED for Pass indication.**
- **Buzzer Output Control for Pass indication.**
- **External RFID Coil Antenna for greater versatility.**
- **5.5V-15V input supply**

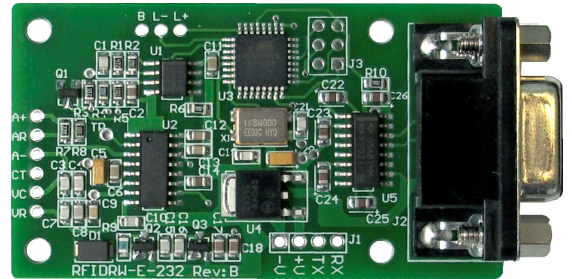

Description.

The RFIDRW-E series is designed to read FDX-B and HDX transponders as defined in ISO11784/11785. It will also read and write the popular range of EM4100, T55xx series, EM4205 / EM4305, and TIRIS series proximity cards and transponders available on the general market. Additionally it is also capable of programming FDX-B protocol into T55xx, EM4205 / EM4305, and HDX protocol into TIRIS RI-TRP-xxxx transponders

In operation the reader will continually scan for either EM4100, T55xx, TIRIS, EM4205 / EM4305, or FDX-B/HDX transponders depending on which type has been selected. The transponder type can be selected by way of pre-defined commands via the Uart Receive line. When the selected transponder is in range it is read and its associated data is transmitted on the Uart Tx line in serial ASCII format.

The command set for the RFIDRW-E describe such functions as:

- Set LED color and function.
- Set Buzzer Function.
- Set Default Transponder type.
- Locate Tag.
- Read Block/Page.
- Read Password Protected Block.
- Write Block/Page.
- Write Password Protected Block.
- Enable/Disable password Protection.
- Set Maximum Block.
- Setup Transponder Configuration.
- Emulate EM4100 with T55xx tag.
- Read FDX-B/HDX transponders and Write T55xx, EM4205 / EM4305.
- Read/Write RI-TRP-Wxxx in HDX animal tag protocol
- Set Reader Active/De-active

Connector Pin Description:

The RFIDRW-E-232 is powered by a DC supply at Lines -V, and V+ on the terminal pad area J1. Command and data information is available on a DB9 connector J2 as standard RS232 protocol. These lines are also connected to the terminal pad area of J1 as TX and RX lines.

Additionally the peripheral control outputs allow a dual color led, and buzzer to be used to give audio and visual PASS indications when a transponder comes within reading range. The peripheral control outputs are available as a terminal pad area marked L+, L-, and B. The LED and buzzer outputs can be controlled by setting various options described further.

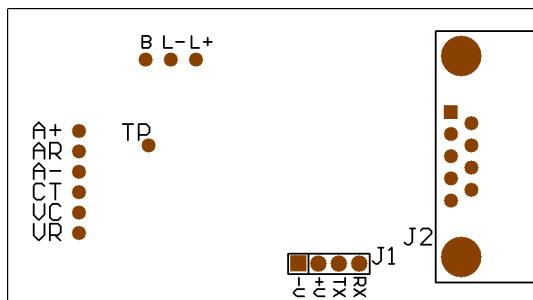

V+ to GND	-0.3V to 15Vdc
RS232 signals	-25V to 25V
Operating Current	38mA (2)
Operating Temperature Range	0° C to 85°C
Storage Temperature Range	0° C to 85°C
Maximum RFID antenna voltage	250Vpp

ABSOLUTE MAXIMUM RATINGS (1)
 NOTE: (1) Stresses above those listed under "Absolute Maximum Ratings" may cause permanent damage to the device. Exposure to absolute maximum conditions for extended periods may affect unit reliability.
 NOTE: (2) Excluding antenna current. May vary due to component variations.

Connector J1 interface lines are described in Table 1.

Pin.	Label.	Description.
1	-V	System Ground line.
2	+V	System power input line. +5.5 to 15V DC
3	TX	Uart TX RS232 output. RFID data and command responses from the μRFID are sent on this line.
4	RX	Uart RX RS232 input. Commands to the μRFID unit are sent on this line.

Table 1. J1 connector interface.

Connector J2, RS232 signal port lines are described in Table 2.

Pin.	Description.
2	Uart TX RS232 output. RFID data and command responses from the μ RFID are sent on this line(1)
3	Uart RX RS232 input. Commands to the μ RFID unit are sent on this line. (1)
5	Signal Ground line.

Table 2. J2 connector interface. RS232 signal port.

Note (1) Pin 2, and 3 are also physically connected to TX and RX line of J1

Peripheral control lines are described in Table 3

Label.	Description.
L+	Positive polarity of led output when dual color led is used.
L-	Negative polarity of LED output when dual color led is used. (1)
B	Buzzer output control line. This line will go high when the buzzer is active.

Table 3. Peripheral Control lines

Note: (1) When using a single color led you may leave L- unconnected, and connect the cathode of the LED to ground.

Operating frequency:

In a RFID reader the antenna is a simple inductor, typically in the form of a coil. When an inductor is coupled to a capacitor and driven by an alternating signal the amplitude of the voltage across the inductor varies depending on the values of the drive frequency, the inductor, and the capacitor. This tuned circuit is illustrated in Figure 1. When the frequency reaches a critical value the voltage across the inductor reaches a maximum value which can be many times the amplitude of the driving voltage. This is known as the resonant frequency. RFID readers typically operate at this resonant frequency to maximize the power transferred to the antenna.

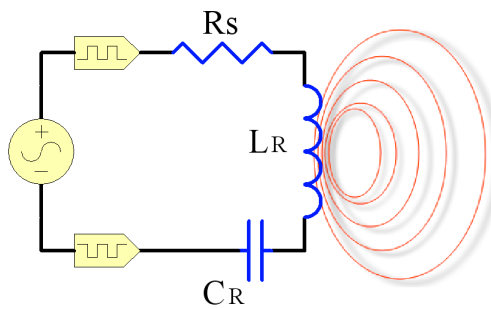

Figure 1. Basic tuned circuit

Where L_R = Inductance of the antenna.
 C_R = Value of Tuning capacitor.
 R_s = Series resistance of the antenna.

The resonant frequency of a tuned circuit can be found using the following formula.

Equation 1.

$$f_0 = \frac{1}{2 \times \pi \times \sqrt{L_R \times C_R}}$$

Where f_0 = the operating frequency
 L_R = is the antenna inductance.
 C_R = value of the tuning capacitor

The antenna drive on the RFIDRW-E uses a self adaptive carrier frequency circuit to locate the antenna resonant frequency. This means that the antenna drive circuit will automatically tune the operating frequency to the antenna and tuning capacitor being used. This maximizes the power transferred to the antenna and increases read range. The drive circuit can operate anywhere in the range from 100 to 150 kHz depending on the values of L_R and C_R .

Connecting the antenna:

The RFIDRW-E has a series of terminal pads for antenna connection and configuration. These connection pads are designated A+, AR, A-, CT, VC, and VR. There is also a connection pad TP which allows the current operating frequency to be measured by a frequency counter. Figure 2 illustrates the antenna drive circuit with a typical antenna connection.

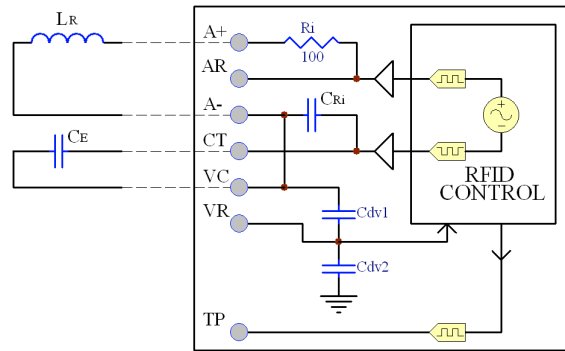

Figure 2. Antenna Drive Interface

This unit is designed to be connected to our standard [RFIDCOIL-49A](#) antenna but can easily be used with other coil antennas. Internal tuning capacitors Cr and Series Resistor Ri preset the unit to operate at 134Khz when used in conjunction with the RFIDCOIL-49A to minimize external components. When used with any other antenna coil a tuning capacitor is required to set the units operating frequency which is typically 125Khz, or 134Khz depending on the transponder type.

As the voltage on a RFID antenna can be much larger than the input circuitry can accept, the voltage being sensed at the antenna is reduced by means of a simple capacitor divider circuit, shown in Figure 6 as Cdv1, and Cdv2. These values are preset to accept a maximum antenna voltage of 350V peak to peak..

The peak to peak voltage that will develop across the antenna coil is determined by the formula:

Equation 2.
$$V_a(p.p) = \frac{2}{f_o \times C_R \times (R_t + 6)}$$
 Where f_o = the operating frequency.
 C_R = is total value of tuning capacitor.
 R_t = sum of any external series resistance and internal antenna resistance.

Also the peak current through the antenna can be determined by:

Equation 3.
$$I_a(peak) = \frac{6.37}{(R_t + 6)}$$
 Where R_t = sum of any external series resistance and internal antenna resistance.

The maximum voltage allowed to exist at the sensing point VR is 4.0V so the voltage divider circuit consisting of Cdv1 and Cdv2 reduces the large antenna voltage to a suitable level. The maximum current (Ia) allowed through the antenna coil must not exceed 200mA.

Antenna connection pads are described in Table 4

Label.	Description.
A+	One side of the antenna coil is connected here, through a 22ohm on board series resistor.
AR	This line is the same as A+ but with the internal 22ohm series resistor bypassed. (1)
A-	The return side of the antenna coil is connected here. Note that A- and VC are internally connected together.
CT	A tuning capacitor is attached between CT and VC (or A-) to tune the unit to the operating frequency. (2)
VC	An additional divisor capacitor may be added between VC and VR to adjust signal strength at VR. (3)
VR	Signal Sense point.

Table 4. Antenna connection lines

Note: (1) This antenna connection is used instead of A+ whenever a series resistor other than the 22ohm internal resistance is required. A series resistor is used to limit the voltage developed across the antenna coil according to equation 2.

Note: (2) An internal tuning capacitor CRi of 532pF exists between A- and CT. Any capacitance added between CT and VC will add to this value. The tuning capacitor then become the sum of CRi and any externally applied capacitor. This value is then used in equation 1 with the antenna inductance to set the operating frequency of the unit.

Note: (3) The capacitor values of Cdv1 and Cdv2 are internally set at 11pF and 1nF respectively. Giving the unit a voltage reduction factor of 92. Any capacitor added across Cdv1 will alter this reduction value according to equation 3.

Equation 4. Voltage reduction factor =
$$\frac{C_{dv2} + C_{dv1} + \text{External capacitor (across VC and VR)}}{C_{dv1} + \text{External capacitor (across VC and VR)}}$$

$$= \frac{1011\text{pf} + \text{External capacitor (across VC and VR)}}{11\text{pf} + \text{External capacitor (across VC and VR)}}$$

Note: It is often required to fine tune a RFID antenna and tuning capacitor circuit to cater for any stray capacitance that occur in a circuit. To obtain a reading of the operating frequency the Measure Operating Frequency command (MOF) may be used.

Example circuit connections:

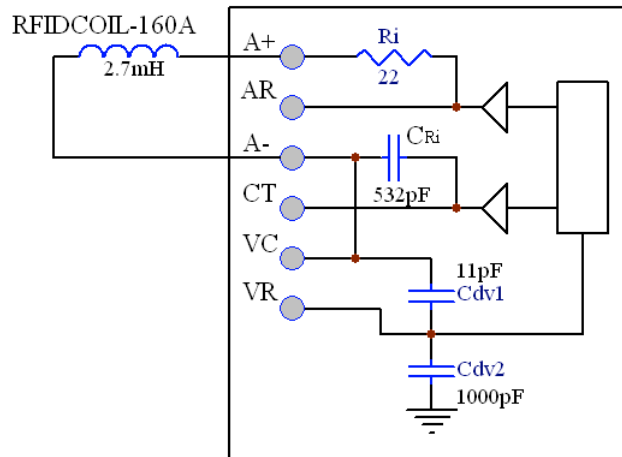

Antenna drive with RFIDCOIL-160A @ 134.4khz

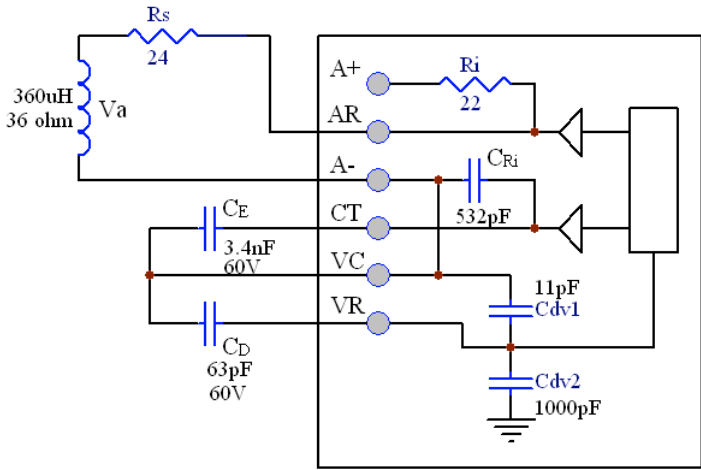

134kHz generic coil design.

$$C_R = \frac{1}{L_R \times (2 \times \pi \times f_o)^2} \quad (\text{from Equation 1})$$

$$C_R = 3.9\text{nF} = C_E + C_{ri} \quad \text{Where } C_{ri} = 532\text{pF}$$

Therefore $C_E \sim 3.4\text{nF}$

$$V_a = \frac{2}{f_o \times C_R \times (R_t + 6)} = \frac{2}{134000 \times 3.9\text{nF} \times 66} = 58\text{V p.p}$$

$$\text{Voltage at VR} = V_a \times \frac{(C_{dv1} + C_D)}{(C_{dv1} + C_D) + C_{dv2}}$$

$$(C_{dv1} + C_D) = \frac{C_{dv2} \times V_R}{V_a - V_R} = \frac{1000\text{pF}(4\text{V})}{58\text{V} - 4\text{V}}$$

$$(C_{dv1} + C_D) = 74\text{pF}, \quad C_D \sim 63\text{pF}$$

$$I_a = \frac{6.37}{(R_t + 6)} = 96.5\text{mA} \quad (<200 \text{ max})$$

A simple circuit connection is shown here including a dual color LED and a Buzzer. Dual color LED's can display 2 colors by driving them with alternating polarity. The RFIDRW-E-232 is designed for dual color LED's but an ordinary single color led may be substituted. The alternate color then simply becomes an OFF LED state. When selecting a Buzzer, one that has a self drive circuit is required.

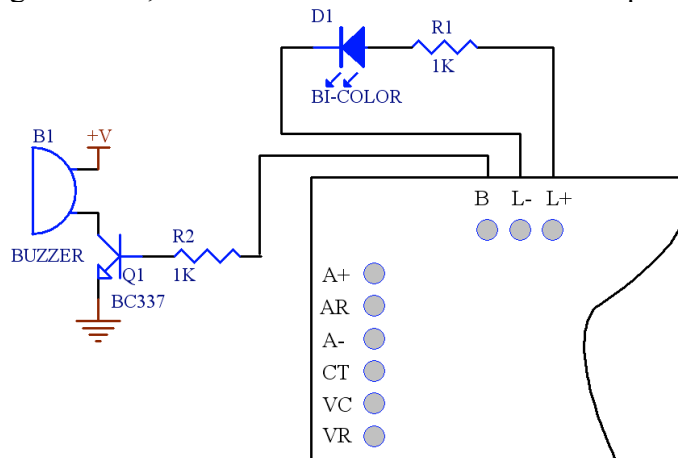

RFID application software:

Our free RFID reader application program allow users to quickly read and write RFID transponders and can be downloaded from <http://www.priority1design.com.au/download.html> Also available for download is our keyboard wedge application which allows users to transfer scanned tag codes to other user applications such as EXCEL, Notepad, or any other application running on a PC that allows keyboard entries to be made. Our more advanced free serial keyboard wedge program Datasnip can be obtained from <http://www.priority1design.com.au/datasnip.zip>

Principle of Operation:

The RFIDRW-E rfid unit generates a magnetic field through an external antenna, usually at 125kHz, or 134kHz. Passive RFID transponders have an integrated antenna that are tuned to the same frequency. When they are within range of the reader unit they are able to draw sufficient power from the electromagnetic field to power their own internal electronics. Once powered they are able to modulate the incident magnetic field which is detected by the reader. In this way the Transponders are able to transmit their data to the reader.

There are many different types of transponders designed to operate at various frequencies, and their functions and the amount of information they carry can also vary. By selecting a suitable antenna and tuning capacitor the RFIDRW-E can be tuned to the same frequency that the transponders being scanned are optimized for. For animal identification transponders this frequency will be 134Khz; however other types of transponders may be at 125Khz .

The unit will read EM4100 compatible transponders carrying 64 bits of read only data, as well as read and write T55xx compatible transponders carrying 224 bits of Read/Write memory using Manchester Encoding, and EM4205 / EM4305 transponders that carry 352 bits of useful information using Biphasic encoding. It is also capable of reading FDX-B and HDX compatible transponders, and programming the T55xx, and EM4205/4305 using FDX-B animal identification protocol.

It can also read and write the TIRIS range of transponders in page mode, while also being able to write the RI-TRP-Wxxx in HDX animal tag mode.

Serial Output Format description:

When a successful read of a transponder takes place the unit will transmit a string of information. This string of information will vary in length depending on the type of transponder being scanned, and the configuration of the transponder.

EM4100 transponder Output

The output format for a read of an EM4100 transponder is a simple string of 10 ASCII coded Hexidecimal characters followed by the ASCII code \$0D (carriage return) as a string end marker.

For example, when reading a EM4100 compatible card with the Version Number of \$06, and a card data of \$001259E3 the following string is transmitted:

06001259E3<crn> where <crn> is serial ASCII code \$0D

The card information is transmitted once and a new string will not be sent until the transponder moves outside of the scanning range, and it, or another transponder enters scanning range again.

NOTE: Although EM4100 compatible transponders contain 64bits of information not all the bits are defined for user data. Some data bits are allocated as parity check bits and for other functions. To see an overview of the EM4100 protocol see http://www.priority1design.com.au/em4100_protocol.html

T55xx transponder Output.

The output format for a read of a T55xx transponder is slightly more complicated than an EM4100 as it has more data and various options that alter its behavior. The memory structure of the T55xx rfid tags is as shown in Fig 3. T55xx memory structure.

Block memory description.	Example data
Page 0,Block 0, 32 bit Configuration data.	Manchester, max block = 4
Page 0,Block 1, 32 bit R/W Data	12665577
Page 0,Block 2, 32 bit R/W Data	99A0FF56
Page 0,Block 3, 32 bit R/W Data	226390AA
Page 0,Block 4, 32 bit R/W Data	56129800
Page 0,Block 5, 32 bit R/W Data	FFFF0000
Page 0,Block 6, 32 bit R/W Data	99880011
Page 0,Block 7, 32 bit R/W Data, or Password	12345678
Page 1, Block 1, 32bit Trace data	-
Page 1, Block 2, 32bit Trace data	-

Fig 3. T55xx memory structure.

When the tag enters the RF field and powers up it loads the information stored in the configuration block. This tells it what bit rate and encoding scheme to transmit in. It then enters into Regular Read Mode. In Regular Read Mode the tag will start to transmit its data starting from Block 1, and ending in the block number selected by a parameter known as the Max Block value stored in the configuration data (block 0). The RFIDRW-E will decode the information coming from the tag and output the data in an ASCII coded string. This is of the form of 8 ASCII hex characters per 32bit block, with each block separated by an ASCII space character \$20. The full string is terminated with a carriage return character \$0D. For example, when reading a T55xx compatible card with the example data shown above and a Max Block set to 4 the following string is transmitted:

12665577 99A0FF56 226390AA 56129800<crn> ,where <crn> is serial ASCII code \$0D

The card information is transmitted once and a new string will not be sent until the transponder moves outside of the scanning range, and it, or another transponder enters scanning range again. However various block access read and write commands are available for the T55xx as described further. For a more detailed description of the T55xx transponder see http://www.priority1design.com.au/T55xx_rfid_transponder.html

FDX-B/HDX animal identification transponder Output

The output format for a read of an FDX-B or HDX protocol transponder is a simple string of decimal characters indicating the 3 digit country code, and 12 digit National ID followed by the ASCII code \$0D (carriage return) as a string end marker.

When a FDX-B/HDX programmed transponder enters the field of the reader it will be scanned and a string as shown in the example below is transmitted:

999_000000001008<crn> ,where <crn> is serial ASCII code \$0D, and “_” is a data separator

In this example 999 is the country code defined inside the transponder, while 000000001008 is the unique 12 digit decimal code used to identify an animal.

FDX-B/HDX protocol transponders may contain additional data which can be accessed using specific commands. See RAT and WAT commands as shown in Table 5. Active Tag Commands Summary further on.

TIRIS 64 bit and Multi-page transponder Output

The TIRIS range of transponders made by Texas Instruments carry 1 or more pages of 64/80 bits of data. For 80 bit transponders the RFIDRW-E will allocate 64 bits as data and use the remaining 16 bits as a CRC check field.

When a TIRIS single or multi-page transponder enters the field of the reader it will be scanned and a string displaying the 64 bits of data for page 1 is output as shown in the example below.

1122334455667788<crn> ,where <crn> is serial ASCII code \$0D.

Block memory description.	Example data
Page 1, 64 bit R/W Data	1122334455667788
Page 2, 64 bit R/W Data	0123456789123456
Page 3, 64 bit R/W Data	99A0FF5666FF0000
.	.
.	.
.	.
.	.
Page 17, 64 bit R/W Data	FF00A10000224456

Fig 4. TIRIS transponder memory structure. Multi-page tag.

EM4205 / EM4305 transponder Output.

The memory structure of the EM4205 / EM4305 rfid tags is as shown in Fig 5. EM4205 / EM4305 memory structure.

Addr. (dec)	Block description.	Type	Example data
0	Chip Type, Res Cap Customer code/ User free	RW	00040072
1	UID number	RA	4408C25C
2	Password	WO	00000000
3	User free	RW	00000000
4	Configuration word	RW	0002008F
5	User free	RW	1009BC00
6	User free	RW	F9E04020
7	User free	RW	EBEE0201
8	User free	RW	8040201D
9	User free	RW	00000000
10	User free	RW	00000000
11	User free	RW	00000000
12	User free	RW	00000000
13	User free	RW	00000000
14	Protection word 1	RP	00008002
15	Protection word 2	RP	00000000

Fig 5. EM4205 / EM4305 memory structure.

When the tag enters the RF field and powers up it loads the information stored in the configuration block. This tells it what bit rate and encoding scheme to transmit in. It then enters into Default Read Mode. In Default Read Mode the tag will start to transmit its data starting from Block 5, and ending in the block number selected by a parameter known as the Last Default Word value stored in the configuration data (block 4) before starting to repeat its data from block 5 again without pause.

The RFIDRW-E will decode the information coming from the tag and output the data in an ASCII coded string, however as the EM4205 / EM4305 does not have any form of end terminator pattern there is no practical way for the reader to know how many words are being transmitted unless the configuration block is read first. As this may be read protected the RFIDRW-E will only transmit the data from block 5. The user may then access the remaining blocks of data as required using the Read Block commands (RBxx) described further.

The Output is of the form of 8 ASCII hex characters per 32bit block. The full string is terminated with a carriage return character \$0D.

For example: 1009BC00<cr> , where <cr> is serial ASCII code \$0D

The card information is transmitted once and a new string will not be sent until the transponder moves outside of the scanning range, and it, or another transponder enters scanning range again. However various block access read and write commands are available for the EM4205 / EM4305 as described further.

RFIDRW-E command description.

Various commands and parameter data are sent to the RFIDRW-E via the serial port. Commands sent to the reader consist of simple ASCII strings terminated with a carriage return. The reader will then process the command and respond by transmitting data or status information serially back through the virtual com port.

The reader has various selectable power up options. These options are written to non-volatile memory within the unit and will be retained even after the unit is turned off. These options are:

- Set LED color and function.
- Set Buzzer Function.
- Set Default Transponder type.

LED and Buzzer functions activate for a short period after a successive read of a transponder. The behavior of which can be controlled by the appropriate command. Setting the default transponder controls which transponder type the reader first starts to look for once it is turned on. See Table 4. Setting power up options.

LED Color While Scanning.	LED color Transponder Read.	Serial Command Code.
RED (default)	GREEN (default)	SL0 <crn>
GREEN	RED	SL1 <crn>
LED OFF	GREEN	SL2 <crn>
LED OFF	RED	SL3 <crn>
LED OFF	LED OFF	SL4 <crn>
RED	RED	SL5 <crn>
GREEN	GREEN	SL6 <crn>

* For purposes of illustration a RED/GREEN dual color led is assumed connected.

BUZZER FUNCTION.	Serial Command Code.
BEEP ON READ(default)	SB0<crn>
BUZZER DISABLED	SB1<crn>

DEFAULT TRANSPONDER	Serial Command Code.
EM4100Read Only	SD0<crn>
T55xx Read/Write Tag	SD1<crn>
FDX-B/HDX (default) Read/Write Tag	SD2<crn>
TIRIS 64 bit / Multi-page Read/Write Tag	SD3<crn>
EM4205/EM4305 Read/Write Tag	SD4<crn>

Table 5. Setting power up options.

<crn>= ASCII carriage return code \$0D

When a command is processed successfully the reader will respond with the standard response of :

OK<crn>

If the command is misunderstood, a status code is sent back. See **Error Codes and Status Description**.

Additionally the RFIDRW-E features the following commands as summarized in Table 6. Active Tag Commands summary.

Command Description	Serial Command Code.
LOCATE TRANSPONDER	LTG<crn>
SELECT TAG TYPE	STx<crn>
READ BLOCK (T55--,TIRIS, EM4----)	RBx<crn>, RBxx<crn>
WRITE BLOCK (T55--,TIRIS, EM4----)	WBx<32bit Data><crn>, WBxx<32bit Data><crn>
READ PASSEWORDED BLOCK (T55--)	RPx<32bit Password><crn>
WRITE PASSEWORDED BLOCK (T55--)	WPx<32bit Password><32bit Data><crn>
SET MAXIMUM BLOCK (T55--)	SMx<crn>
ENABLE PASSWORD PROTECTION (T55--,EM4----)	PWE<crn>
DISABLE PASSWORD PROTECTION (T55--,EM4----)	PWD<32bit Password><crn>
READ CONFIGURATION BLOCK (T55--)	RCB<crn>
SETUP CONFIGURATION BLOCK (T55--,EM4----)	SCB<crn>
WRITE EM4100 PROTOCOL (T55--)	WEP<40bit Data>
READ TRACE DATA (T55--)	RTD<crn>
READ STANDARD DATA	RSD<crn>
READ ANIMAL TAG (FDX-B/HDX)	RAT<crn>
WRITE ANIMAL TAG (FDX-B/HDX)	WAT<crn>
WRITE SPECIAL REGISTER (EM4---)	WSRx<crn>
SET READER DE-ACTIVE	SRD<crn>
SET READER ACTIVE	SRA<crn>
MEASURE OPERATING FREQUENCY	MOF<CRN>
READ FIRMWARE VERSION CODE	VER<crn>

Table 6. Active Tag Commands Summary.

x denotes block address
(T55--) denotes T55xx tag commands only
(FDX-B/HDX) denotes FDX-B/HDX protocol tag commands.
(TIRIS) denotes TIRIS 64 bit / Multi-page tag commands.
(EM4---) denotes EM4205 / EM4305 protocol tag commands.

Locate Transponder Command.

When a transponder enters the scanning field of the reader its data is decoded and transmitted on the Uart Tx line; however once data is sent there is no indication that the tag is still within scanning range. At some point it may have been removed. The Locate Transponder commander is useful in determining if a tag is still present. The command protocol for which is shown here, along with the available responses.

Protocol: **LTG<crn>** ,where <crn> is \$0D carriage return.

Command Protocol Example	Response.	Description.
LTG<crn>	?1<crn>	Tag not present
	OK<crn>	Tag present

Select Tag Type Command.

This command is almost identical to the Set Default Transponder command, except that the parameters are not stored to non volatile memory. On power up the selected tag will always revert back to that set using the Set Default Transponder command.

This command is used for alternating between scanning for one type of transponder and another. A user may elect to scan for an EM4100 tag during, for example, a 1 second period and a T55xx tag the next, in alternating fashion.

Special Note: The Select Tag command also introduces a 5 second lockout of the reader's normal Pass indication and serial output. If a tag enters the field within 5 seconds of issuing this command it will not transmit the card data, or issue LED and buzzer indications. This is to prevent contradictory data being sent to any scanning program accessing the reader while a tag enters the scanning field.

Protocol: **STx<crn>** ,where x = tag type code 0 to 1, <crn> is \$0D carriage return.

Command Protocol Example	Response.	Description.
ST0<crn>	OK<crn>	EM4100 Tag selected
ST1<crn>	OK<crn>	T55xx Tag selected
ST2<crn>	OK<crn>	FDX-B / HDX Tag selected
ST3<crn>	OK<crn>	TIRIS Tag selected
ST4<crn>	OK<crn>	EM4205 / EM4305 Tag selected

Read Block(Page) Command.

This command is valid for T55xx, TIRIS, or EM4205 / EM4305 transponders not in password protected mode. The protocol used varies depending on whether a T55xx , TIRIS or EM4205 / EM4305 tags are selected for scanning.

Protocol: **RBx<crn>** ,T55xx tag, where x is the block address 1 to 7, <crn> is \$0D carriage return.
RBxx<crn> ,TIRIS tag, where xx is the page address 1 to \$11 in hexadecimal
, EM4205 / EM4305, where xx is the page address in Hexidecimal format.

Command Protocol Example T55xx	Response.	Description.
RB1<crn>	?1<crn>	Tag not present
.	aabbccdd<crn>	8 ASCII hex bytes representing
.		1 block of 32bit data is returned
RB7<crn>		

If this command is sent while the tag is in password mode, the command will be ignored by the transponder and it will revert to standard read mode. In this case the returned information will be one or more blocks of 32bit data depending on the Max Block setting stored within the transponder configuration block.

Command Protocol Example TIRIS	Response.	Description.
RB01<crn>	?1<crn>	Tag not present
.	1122334455667788<crn>	16 ASCII hex bytes
.		Page 1 data is returned
RB11<crn>	?1<crn>	Tag not present
	?4<crn>	Page address invalid
		for this tag.
	FF00A10000224456<crn>	16 ASCII hex bytes
		Page 17 data is returned

Error code 4 (?4) is issued when a page address is invalid. This occurs when a 64 bit tag is being scanned which only carry 1 page of data.

EM4205 / EM4305

Command Protocol Example

Response.

Description.

RB01<crn>	?1<crn>	Tag not present
.	11223344<crn>	8 ASCII hex bytes
.	?2<crn>	Bad Read, possibly
.		password protected,
		wrong address.
RB0F<crn>	?1<crn>	Tag not present
	00008002<crn>	8 ASCII hex bytes

Standard read response for an EM4100 transponder.

Command Protocol Example

Response.

Description.

RB1<crn>	?1<crn>	Tag not present
.	?2<crn>	Invalid read or Write for
.		EM4100 data.
RB7<crn>		

Write Block(Page) Command.

This command is valid for T55xx, TIRIS, or EM4205 / EM4305 transponders not in password protected mode. The protocol used varies depending on whether a T55xx , TIRIS or EM4205 / EM4305 tags are selected for scanning.

Protocol: **WBx<32bit Data><crn>** ,T55xx tag, where x is the block address 1 to 7,
 <crn> is \$0D carriage return.
WBxx<64bit Data><crn> ,TIRIS tag, where xx is the page address 1 to 17 in Hexidecimal
WBxx<32bit Data><crn> , EM4205 / EM4305, where xx is the page
 address in Hexidecimal format

Command Protocol Example T55xx	Response.	Description.
WB1aabbccdd<crn>	?1<crn>	Tag not present
.	?2<crn>	Tag failed to Write
.	OK<crn>	Data written. (aabbccdd)
WB7aabbccdd<crn>		

If this command is sent while the tag is in password mode, the command will be ignored by the transponder

Command Protocol Example TIRIS	Response.	Description.
WB010123456789123456<crn>	?1<crn>	Tag not present
.	?2<crn>	Tag failed to Write
.	OK<crn>	Data written.
.		Page 1 = 0123456789123456
.		
WB11FFAA444455556666<crn>	?1<crn>	Tag not present
	?2<crn>	Tag failed to Write
	?4<crn>	Page address invalid
		for this tag.
	OK<crn>	Data written.
		Page 17 = FFAA444455556666

Error code 4 (?4) is issued when a page address is invalid. This occurs when a 64 bit tag is being scanned which only carry 1 page of data.

EM4205 / EM4305

Command Protocol Example	Response.	Description.
WB05aabbccdd<crn>	?1<crn>	Tag not present
.	?2<crn>	Tag failed to Write
.	OK<crn>	Data written to block 5.
WB0Daabbccdd<crn>		(aabbccdd)

Read Passworded Block Command.

This command is only valid if the T55xx transponder is selected, and the tag is in password mode. T55xx Transponders have 7 blocks of 32bits of read/write memory. The blocks are addressed in the range of block 1 to block 7. It is used to read the 32bits of data of a selected block with password protection.

Protocol: **RPx<32bit Password><crn>** ,where x is the block address 1 to 7, <crn> is \$0D carriage return and 32bit password is expressed as 8 ASCII hex bytes.

Command Protocol Example	Response.	Description.
RP1FFAACCC00<crn>	?1<crn>	Tag not present
.	aabbccdd<crn>	8 ASCII hex bytes representing
.		1 block of 32bit data is returned
RP7FFAACCC00<crn>		

If this command is sent while the tag is not in password mode, the command will be ignored by the transponder and it will revert to standard read mode. In this case the returned information will be one or more blocks of 32bit data depending on the Max Block setting stored within the transponder configuration block.

Write Passworded Block Command.

This command is only valid if the T55xx transponder is selected, and the tag is in password mode. T55xx Transponders have 7 blocks of 32bits of read/write memory. The blocks are addressed in the range of block 1 to block 7. It is used to write 32bits of data to a selected block with password protection.

Protocol: **WPx<32bit Password><32bit Data><crn>** ,where x is the block address 1 to 7, <crn> is \$0D carriage return, and 32bit password is expressed as 8 ASCII hex bytes.

CAUTION. Only issue this command if the Tag is in Password protection mode otherwise data corruption may occur. A transponder that is not in password mode will misinterpret the password for data and an incorrect write will occur.

Command Protocol Example	Response.	Description.
WP112345678aabbccdd<crn>	?1<crn>	Tag not present
.	?2<crn>	Tag failed to Write
.	OK<crn>	Data written. (aabbccdd)
WP712345678aabbccdd<crn>		

In this example the password is \$12345678 stored in block 7

Set Maximum Block Command.

This command is only valid if the T55xx transponder is selected, and the tag is not in password mode. As discussed earlier in this document the T55xx transponders enter Standard Read mode when they first enter the RF field of the reader. In this mode they will start transmitting data from block 1 to a block address defined in the configuration block. This value is the Max Block value and can be any value from 0 to 7. If the password mode is to be used for the tag then the maximum block should not be set to 7 as this will cause the password that is stored in block 7 to be transmitted. Note also that if the maximum block is set to 0 this will cause the configuration block to be transmitted only.

This command is useful when an application requires that part of the data stored on the tag be automatically transmitted, in other words “public data”, while the upper blocks remain private, readable only through a direct block read command.

Protocol: **SMx<crn>** ,where x is the Max Block value required (0 to 7), <crn> is \$0D carriage return.

Command Protocol	Response.	Description.
SM0<crn>	?1<crn>	Tag not present
.	?2<crn>	Tag failed to Write
.	OK<crn>	Max value Set ok.
SM7<crn>		

Enable Password Protection.

This command is valid for T55xx tags not in password mode, or EM4205 / EM4305 transponders. This command does a write to the configuration block of the tag and sets the Password control bits.

Following this command all direct block access commands for the T55xx tag require a password to be sent. The EM4205 / EM4305 requires a login command to be sent before block access command can be sent. See Write Special Register command (WSRx) further.

Note that when a T55xx tag first enters scanning range it will start transmitting from block 1 to the value set by the Max Block parameter. If there are locations that are required to be kept private a Max Block value below that required to be private should be set.

Protocol: **PWE<crn>** ,where <crn> is \$0D carriage return.

Command Protocol	Response.	Description.
PWE<crn>	?1<crn>	Tag not present
	?2<crn>	Tag failed to Write
	OK<crn>	Password mode enabled.

Disable Password Protection.

This command is only valid if the T55xx, or EM4205 / em4305 transponder is selected, and the tag is in password mode.

This command performs a write to the configuration block of the tag and clears the Password control bits. Following this command all direct block access commands do not require a password or a login to be sent.

Protocol: **PWD<32bit Password><crn>** ,where <crn> is \$0D carriage return.

Command Protocol	Response.	Description.
PWD<12345678><crn>	?1<crn>	Tag not present
	?2<crn>	Tag failed to Write
	OK<crn>	Password mode disabled.

In this example the password is \$12345678 stored in block 7 for the T55xx, or block 2 for the EM4205 / EM4305

CAUTION. For T55xx tags only issue this command if the Tag is in Password protection mode otherwise data corruption may occur. A transponder that is not in password mode will misinterpret the password for data and an incorrect write will occur. As this command accesses the configuration block writing incorrect data to this block may render the tag unreadable. This can occur if the tag is set to operate with an encoding scheme other than one that the RFIDRW-E is designed to operate with.

Read Configuration Block Command.

This command is only valid if the T55xx transponder is selected, and the tag is not in password mode. This command is used to read the configuration block (block 0).

Protocol: **RCB<crn>** ,where <crn> is \$0D carriage return.

Command Protocol	Response.	Description.
RCB<crn>	?1<crn>	Tag not present
	aabbccdd<crn>	8 ASCII hex bytes representing the 32bit configuration block.

Setup Configuration Block Command.

This command is valid for T55xx and EM4205 / EM4305 tags that are not in password mode.

The RFIDRW-E currently only reads T55xx tags setup for Manchester Encoding, 32cyc/bit, with Sequence terminator active, and EM4205 / EM4305 tags using Biphase 32cyc/bit . This is usually the default factory setting for tags however the user may encounter transponders setup otherwise. If the configuration block has not been locked, or password protected the use of this command will set the transponder to the appropriate mode for this reader.

Protocol: **SCB<crn>** ,where <crn> is \$0D carriage return.

Command Protocol	Response.	Description.
SCB<crn>	?2<crn>	Tag failed to Read/Write
	OK<crn>	Tag setup successfully.

Write EM4100 Protocol Command.

This command is only valid if the T55xx transponder is selected, and the tag is not in password mode. EM4100 protocol tags are Read Only and their data is factory set. This presents a problem when a duplicate tag, or a tag with predefined data is required. This command solves this problem by writing the data and configuration block of a T55xx Read/Write tag so that it appears to function as a EM4100 tag to a standard reader.

Protocol: **WEP<40 bit data><crn>** ,where <crn> is \$0D carriage return.

Command Protocol	Response.	Description.
WEP1200071239<crn>	?1<crn> OK<crn>	Tag not present T55xx Tag will now function as a EM4100 tag.

In this example the T55xx Tag will now behave as an EM4100 protocol Tag with a Version Number of \$12, and a data of \$00071239. The RFIDRW-E will still be selected for T55xx tags after this command. To read the Tag with the new protocol a Set Tag Type command (STx), or Set Default Tag (SDx) will need to be sent in order to read EM4100 protocol tags. In order to return the T55xx tag to its normal function a Setup Configuration Block (SCB) command can be used.

Read Trace Data Command.

This command is only valid if the T55xx transponder is selected, and the tag is not in password mode. This command is used to read the two blocks of Trace information stored in page 1 of the T55xx transponders. These are Read Only blocks and carry manufacturer codes, lot numbers, and other such data for tracing the source of the transponder.

Protocol: **RTD<crn>** ,where <crn> is \$0D carriage return.

Command Protocol	Response.	Description.
RTD<crn>	?1<crn> E0150156 1411081C<crn>	Tag not present 2 x 8 ASCII hex bytes representing 2 blocks of Trace data.

Read Standard Data.

This command is valid for all transponder types. It is used to tell the reader to output the tag’s standard data that it normally transmits when it first enters the RF field of the reader. This command is generally used in conjunction with the Set Tag command for continuous polling purposes. The Set Tag command is first issued, which creates a 5 second lockout of the normal serial communications. During this 5 second window the Read Standard Data command is issued to read the data of any tag currently within scanning range.

Protocol: **RSD<crn>** ,where <crn> is \$0D carriage return.

Command Protocol	Response.	Description.
RSD<crn>	?1<crn> E0150156 1411081C<crn>	Tag not present Standard data for Tag.

Read Animal Tag Data .

This command is only valid if a FDX-B/HDX transponder is selected. This command is used to read information on a transponder encoded using FDX-B or HDX animal identification protocol as defined in ISO11784/11785.

Protocol: **RAT<crn>** ,where <crn> is \$0D carriage return.

Response:

country code _ national identity code _ animal bit status _ data block status _ checkbits _ data block <crn>
 ,where <crn> is \$0D carriage return.
 , “ _ “ is a separator between data fields

Country code is a 3 decimal digit value used to refer to individual manufacturers. A code of 999 is used to indicate that the transponder is a test transponder and need not contain a unique identification number.

National identity code is an unique 12 digit decimal number within a country.

Animal bit status is a single digit indicating whether the transponder is used for animal identification or not. This value is set to 1 to indicate an animal identification application, and 0 otherwise.

Data block status is an indicator flag to indicate whether an additional data block exists. A value of 1 indicates that the transponder contains an additional 24 bit data block. Otherwise it is 0.

Checkbits are a 16 bit cyclic redundancy value used to check the data within a transponder.

Data Block is the information contained in the extra data block if the Data block status is 1. When the Data block status flag is 0 this value will be transmitted as 000000.

Eg.

Command Protocol	Response.	Description.
RAT<crn>	?1<crn> 999_000000001007_1_0_AEC4_000000<crn>	Tag not present String data response

Write Animal Tag Data .

This command is only valid if a FDX-B / HDX transponder is selected. This command is used to write information onto a T55xx, TIRIS, or EM4205 / EM4305 transponders encoded according to FDX-B animal identification protocol as defined in ISO11784/11785.

Protocol: **WAT<country code>_<national identity code>_<animal bit status>_<data block>_<transponder type> <crn>**
 , where <crn> is \$0D carriage return.
 , data block field may be omitted if not required.
 , Transponder type is “0” for T55xx transponders.
 “1” for TIRIS 64 bit transponders HDX
 “2” for EM4205 / EM4305

Country code is a 3 decimal digit value used to refer to individual manufacturers. A code of 999 is used to indicate that the transponder is a test transponder and need not contain a unique identification number.

National identity code is an unique 12 digit decimal number within a country.

Animal bit status is a single digit indicating whether the transponder is used for animal identification or not. This value is set to 1 to indicate an animal identification application, and 0 otherwise.

Data Block is a 6 Hexidecimal string denoting the 24 bits of data to be written into the extra data block of the transponder. If the transponder does not require an extra data block this field may be omitted.

TIRIS 64 bit tags do not store extra data fields so this may be omitted when a TIRIS tag is selected.

Eg.

Command Protocol	Response.	Description.
WAT999_000000001007_1_0<crn>	?1<crn> OK<crn>	Tag not present Write performed.

Country code is 999, National identity code is 000000001007, and Animal status bit set to animal application. In this form there is no extra data block appended. Transponder type is T55xx. Data block status bit is automatically set to 0 as the extra data block information has not been included in the command string. In this case the extra data block is set to \$000000.

Eg.

Command Protocol	Response.	Description.
WAT999_000000001007_1_123456_0<crn>	?1<crn> OK<crn>	Tag not present Write performed.

Country code is 999, National identity code is 000000001007, and Animal status bit set to animal application. Extra data block contains \$123456. The Data Block status bit is automatically set to 1 to indicate the presence of the data block. Transponder type is T55xx.

Eg.

Command Protocol	Response.	Description.
WAT999_000000001007_1_123456_2<crn>	?1<crn> OK<crn>	Tag not present Write performed.

Country code is 999, National identity code is 000000001007, and Animal status bit set to animal application. Extra data block contains \$123456. The Data Block status bit is automatically set to 1 to indicate the presence of the data block. In this example transponder type is EM4205 / EM4305

Write Special Register Command.

This command is valid for the EM4205 / EM4305 transponder when selected.

When used with the EM4205 / EM4305 transponder this command is used to send a login command to the tag in order to gain read and write access while the tag is in password protected mode, or to gain write access to the protection bits.

Protocol: **WSRx<32bit data><crn>** , where x = 1 for login EM4205 / EM4305
, x = 2 to write protection bits EM4205 / EM4305
, <crn> is \$0D carriage return.

Eg.

Command Protocol	Response.	Description.
WSR1<FFFF0101><crn>	?2<crn>	Login not successful.
	OK<crn>	Login successful.

Where in this example \$FFFF0101 is the password stored into block 2 of the EM4205 / EM4305.

WSR2<00000001><crn>	?2<crn>	Write not successful.
	OK<crn>	Write successful.

Where in this example 00000001 is the 32 bit protection bit data of the EM4205 / EM4305. Only bits 0-15 are valid, the rest are don't care. Once you set a bit in the protection register it can't be cleared.

Set Reader De-active Command.

This command is used to turn off the RF field emitted by the reader. Tags can not be scanned while in this mode. This mode is used to prevent the RF field of the reader from interfering with other readers in the vicinity.

The command protocol for which is shown here, along with the available responses.

Protocol: **SRD<crn>** ,where <crn> is \$0D carriage return.

Command Protocol Example	Response.	Description.
SRD<crn>	OK<crn>	RF field is turned off

On power up the RFIDRW-E will default to Reader Active mode.

Set Reader Active Command.

This command is used to turn on the RF field emitted by the reader after it has been turned off using the Set Reader De-active Command. Tag scanning will resume in this mode.

The command protocol for which is shown here, along with the available responses.

Protocol: **SRA<crn>** ,where <crn> is \$0D carriage return.

Command Protocol Example	Response.	Description.
SRA<crn>	OK<crn>	RF field is turned on.

Measure Operating frequency command.

This unit allows for an external antenna to be connected. For proper operation the specification of this antenna should be chosen in conjunction with the tuning capacitors so that the circuit operates at 134.4kHz for optimal read range. To assist in tuning your antenna the Measure Operating frequency command may be used. This will cause the unit to take a measurement and report the operating frequency of the connected antenna.

Protocol: **MOF<crn>** ,<crn> is \$0D carriage return.

Command Protocol Example	Response.	Description.
MOF<crn>	134.2<crn>	Measured frequency = 134.2 kHz

This operation will require 1 second for the measurement to be taken and a response issued.

READ FIRMWARE VERSION CODE.

This command is used to read the firmware version number of the reader.

Protocol: **VER<crn>** , crn> is \$0D carriage return.

Eg.

Command Protocol	Response.	Description.
VER<crn>	206<crn>	Current Version number.

Error Codes and Status Description.

The RFIDRW-E unit will respond to every command with either the requested data, or one of these status strings summarized here.

ERROR AND STATUS CODES.	DESCRIPTION.
?0<crn>	Command not understood.
?1<crn>	Tag not present.
?2<crn>	Tag failure to Read/Write.
?3<crn>	Access to Block 0 not allowed
?4<crn>	Page address invalid for this tag.
OK<crn>	Function Performed Successfully.

Table 4. Error Codes and Status Description summary.

Serial protocol description:

The protocol for the Serial Input and Output lines is 9600 Baud, 8 data bits, 1 stop bit, no parity.

Limitations of the RFIDRW-E.

The T55xx transponders are capable of being set up with various encoding schemes and bit rates. However the RFIDRW-E currently only reads transponders using Manchester Encoding schemes at a bit rate of 32 cycles per bit, with the Sequence terminator pattern active. For this reason limitations have been placed on Write executions to the configuration block in order to prevent accidentally placing the transponders into an unreadable mode of operation.

EM4205 / EM4305 transponders can only be read if using Biphase encoding at 32 cycles per bit.

For applications regarding other encoding schemes, bit rates, and transponder types please contact our technical department via our web site at <http://www.priority1design.com.au/>

The effects of noise on the RFIDRW-E.

Reading a passive RFID transponder requires a sensitive receiver to read the data over the reading distance of the tag. As this requires detecting minute signals any electrical noise in the environment will affect read range. It is advisable to use a well regulated voltage supply free of additional noise otherwise read and write range can be drastically reduced. In addition the presence of noisy electronics such as high speed microprocessors, switch mode power supplies, or signals from other noisy sources such as USB interfaces will also impact the readers performance.

Dimensions:

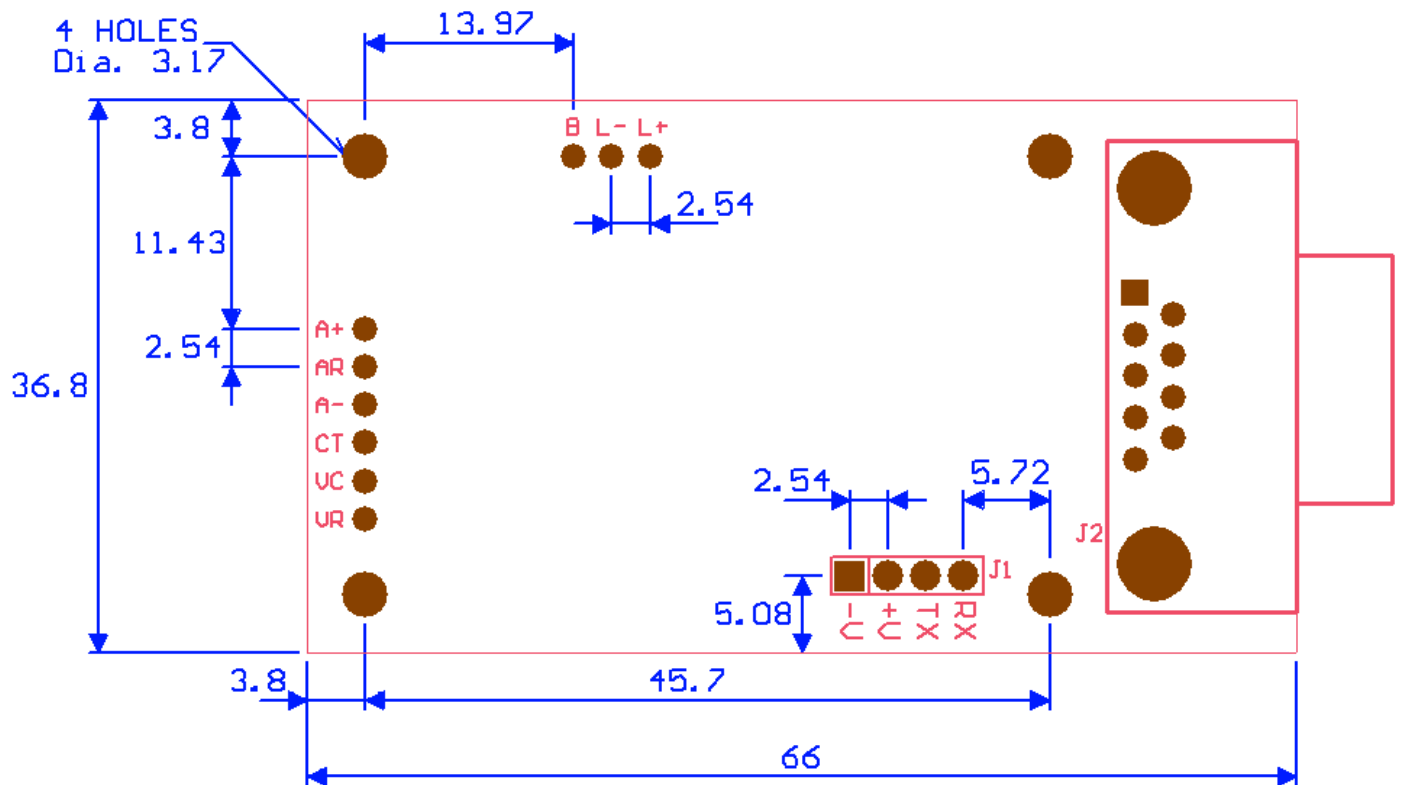

All dimensions in Millimeters.

Disclaimers.

Priority 1 Design reserves the right to change specifications and prices at any time and without notice. Priority 1 Design shall not be liable to recipients or any third party for any damages, including but not limited to personal injury, property damage, loss of profits, loss of use, interrupt of business or indirect, special incidental or consequential damages, of any kind, in connection with or arising out of the furnishing, performance or use of products supplied, or the technical data herein. No obligation or liability to recipient or any third party shall arise or flow out of Priority 1 Design rendering of technical or other services.

Life support — This product is not designed for use in life support appliances, devices, or systems where malfunction of these products can reasonably be expected to result in personal injury. Priority 1 Design customers using or selling this product for use in such applications do so at their own risk and agree to fully indemnify Priority 1 Design for any damages resulting from such application.